



Nitoseal 290*

Flexible polyester loop and lighting sealant

Uses

For sealing horizontal cable slots in concrete and asphalt pavements associated with :

- Road traffic signals and inductance loops
- Airport runway lighting
- Automatic barriers or gates

Advantages

- Excellent adhesion to concrete, asphalt and steel
- No primer required in dry or damp conditions
- Good resistance to chemicals, de-icing salts and hydrocarbons
- Slightly flexible to accommodate limited movement
- Fast cure at 20°C and above minimises traffic disruption
- Can be applied at low temperatures, cures below freezing
- Available in black for use on asphalt and grey for use on concrete

Description

Nitoseal 290 two-component flexibilised polyester based sealant cures to form a tough resilient seal with a limited degree of movement. The material is self levelling and can be poured or gunned directly into horizontal slots.

Nitoseal 290 will adhere to both concrete and asphalt surfaces that have been well prepared whether dry or damp.

Design criteria

In the case of sawn cable grooves with no movement the cable should be totally sealed and encapsulated within the Nitoseal 290 to the top of the groove.

Where movement is anticipated in the sawn joint, cables should be laid free at the base of the saw cut. An oversized closed-cell foamed polyethylene cord should be located above the cables acting as a bond breaker and gasket with the upper joint then sealed using Nitoseal 290.

The same details should apply to movement joints around airfield lights using an oversized closed-cell foamed polyethylene cord as a bond breaker and gasket with the upper joint then sealed using Nitoseal 290.

Typical examples of sealant width/depth ratios (moving joints only)

Groove width (mm)	Sealant depth (mm)
6 - 10	10 minimum
10 - 20	As width
20 plus	20 maximum

In all cases the sealant should be finished flush with the pavement surface.

Properties

The following results were obtained at a temperature of 20°C unless otherwise specified.

Specific gravity	: 1.8
Pot life	: 20 mins at 35°C 45 mins at 20°C
Initial cure	: 30 mins at 35°C 60 mins at 20°C
Shore A hardness	: 90 @ 7 days
Compressive strength (BS 6319 Part 2)	: 17 N/mm ² @ 7 days
Flexural strength (BS 6319 Part 3)	: 12 N/mm ² @ 7 days
Linear shrinkage (ASTM C531.74)	: 0.5%
Water absorption (ASTM C413)	: 0.15%
Electrical properties	
DC insulation resistance (2500 volts)	: >2.5x10 ⁹ Ohms
Dielectric strength step by step (ASTM D149)	: 12.5kV/mm
Chemical resistance	
Salt water, Saturated urea	
Petrol & Aviation fuel	: Excellent
Weathering properties	
QUV Weatherometer 1000 hours (ASTM G53.77):	Slight discolouration

Nitoseal 290*

Instructions for use

Joint preparation

Concrete and asphalt

After cutting the required groove, all laitance or slurry from the water lubricated saw blade must be completely blown out whilst wet using oil-free compressed air. Flush grooves with clean water prior to blowing if required. It is not necessary to completely dry the groove.

Any slurry that has been allowed to dry, or powdered dust from dry cutting operations should be power wire brushed or abrasive blasted from the groove, followed by blowing with oil-free compressed air.

This also applies to concrete or asphalt faces around lighting units that have been formed previously using a water lubricated diamond coring tool.

Steel

If bare metal, the joint faces around lighting units or posts should be abrasive blasted to remove all traces of corrosion. If aluminium, alloy or coated metals are to be sealed, the surfaces should be degreased using Fosroc Solvent 102* and allowed to dry for 5 minutes before sealing.

The correct width/depth profile may be achieved by the installation of a foam backing cord. Alternatively, sand may be used to encapsulate loop wire whilst acting as a bond breaker for the joint sealant.

To obtain neat straight edged seals, masking tape should be applied to both edges of the joint prior to sealing, the masking tape should be removed immediately following the completion of the works.

Mixing

The two components of Nitoseal 290 are supplied in the correct proportions for mixing. Pour the entire contents of the liquid resin into a suitable mixing vessel and then slowly add the powder component whilst mixing with a slow speed drill (300 to 500 rpm) fitted with a Fosroc Sealant Mixing Paddle (MR2). Thoroughly mix the components for not less than three minutes ensuring a homogeneous consistent mix.

Application

Groove sealing

Following thorough mixing, pour the Nitoseal 290 directly into the prepared groove using a spouted container, watering can or other suitable means. It may be practical and convenient to fill narrow grooves using a Fosroc 'G' gun fitted with a plastic nozzle, which if necessary can be cut to size to suit the joint width.

Cleaning

Uncured Nitoseal 290 can be cleaned using Fosroc Solvent 102. Cured Nitoseal 290 can only be removed by mechanical means.

Any spillages of Nitoseal 290 should be absorbed immediately onto sand, sawdust or other suitable absorbent materials. Disposal should be in accordance with local regulations.

Limitations

- Applications should not commence if the temperature of the substrate is below 5°C.
- Service temperature range of Nitoseal 290 is from - 30°C up to + 80°C.

Technical support

Fosroc offers a comprehensive range of high performance, high quality repair, maintenance and construction products. In addition, Fosroc offers a technical support package to specifiers, end-users and contractors, as well as on-site technical assistance in locations all over the world.



Nitoseal 290*

Typical Joint Details

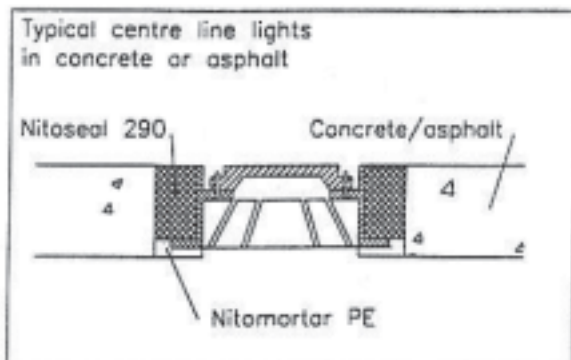
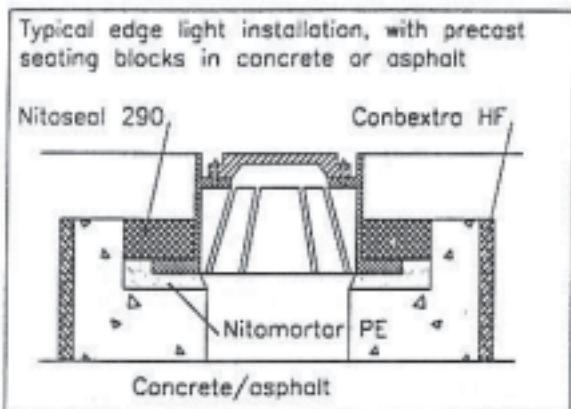
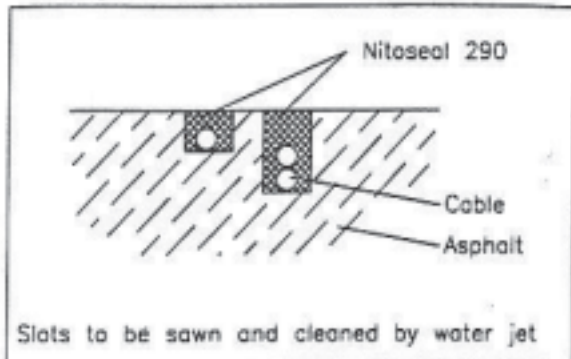

Estimating

Supply

Nitoseal 290	:	10 litre packs
Fosroc Solvent 102	:	5 litre cans

Guide to sealant quantities

Number of litres required =
Joint width (mm) x groove depth (mm) x groove length (m)
1000

Adjustment should be made where necessary for the volume of the cable. A further amount should be allowed for possible wastage

Storage

Shelf life

6 months if stored in the original unopened containers in a cool dry place at ambient temperatures below 25°C. Do not store in direct sunlight.

Precautions

Health and safety

Some people are sensitive to resins, hardeners and solvents. Wear suitable protective clothing, gloves and eye/face protection. Barrier creams such as Kerodex Antisolvent or Rozalex Antipaint provide additional skin protection.

Should accidental skin contact occur, remove immediately with a resin removing cream such as Kerocleanse Standard Grade Skin Cleanser or Rozaklens Industrial Skin Cleanser, followed by washing with soap and water. Do not use solvent.

In case of contact with eyes, rinse immediately with plenty of clean water and seek medical advice.

If swallowed, seek medical attention immediately - do not induce vomiting.

Fire

Nitoseal 290 and Fosroc Solvent 102 are flammable. Keep away from sources of ignition. No smoking. In the event of fire extinguish with CO₂ or foam. Do not use a water jet.

Flash points

Nitoseal 290	:	28°C
Solvent 102	:	33°C

For further information, refer to the Product Material Safety Data Sheet.

Nitoseal 290*

Additional Information

Fosroc manufactures a wide range of complementary products which include :

- waterproofing membranes & waterstops
- joint sealants & filler boards
- cementitious & epoxy grouts
- specialised flooring materials

Fosroc additionally offers a comprehensive package of products specifically designed for the repair and refurbishment of damaged concrete. Fosroc's 'Systematic Approach' to concrete repair features the following :

- hand-placed repair mortars
- spray grade repair mortars
- fluid micro-concretes
- chemically resistant epoxy mortars
- anti-carbonation/anti-chloride protective coatings
- chemical and abrasion resistant coatings

For further information on any of the above, please consult your local Fosroc office - as below.

* Denotes the trademark of Fosroc International Limited

† See separate data sheet



Important note

Fosroc products are guaranteed against defective materials and manufacture and are sold subject to its standard Conditions for the Supply of Goods and Service

Al Gurg Fosroc
LLC

Post Box 657, Dubai
United Arab Emirates

www.fosroc.com

Head Office

telephone: (+9714) 2858606

fax: (+9714) 2859649

email: agf@fosroc.com

Regional offices

Dubai, Al Gurg Fosroc
Abu Dhabi, Al Gurg Fosroc
Bahrain, YBA Kanoo
Kuwait, Boodai
Oman, Al Amana
Qatar, Tadmur

telephone: 285 8787
telephone: 673 1779
telephone: 17735454
telephone: 4817618
telephone: 771 5080
telephone: 413628

fax: 285 2023
fax: 673 1449
fax: 17732828
fax: 4832124
fax: 771 7554
fax: 440812

email: dubai@fosroc.com
email: abudhabi@fosroc.com
email: bahrain@fosroc.com
email: kuwait@fosroc.com
email: oman@fosroc.com
email: qatar@fosroc.com



UAE/0326/01/B